

R3C MALE COAX CAB 5/50

R299.197.030

CONDITIONNEMENT BOBINE 2300

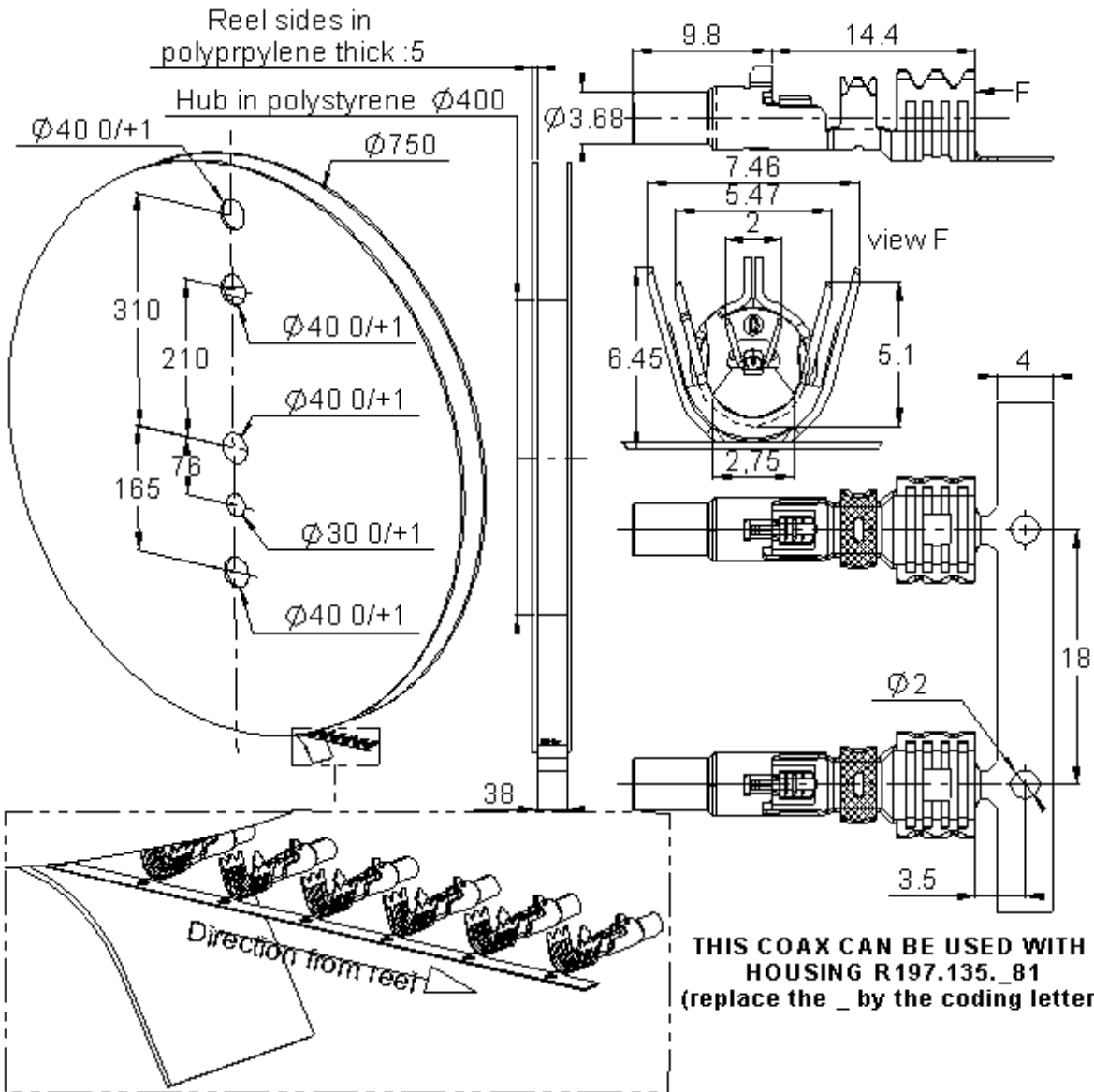

All dimensions are in mm.

COMPONENTS	MATERIALS	PLATING (µm)	
BODY	BRONZE	TIN 3 OVER NICKEL 2	
CENTER CONTACT	BRONZE	SELECTIVE GOLD+ SELECTIVE TIN	
OUTER CONTACT	-	-	
INSULATOR	POLYMER	UL CLASSIFICATION	COLOR
	-	UL94-V0	NATURAL
	-		

Standard Packaging : 2300+/-2%*

* Nota : possibility of having a maximum of five missing parts consecutively on the tape

Issue : 0748 B

In the effort to improve our products, we reserve the right to make changes judged to be necessary.



R3C MALE COAX CAB 5/50

CONDITIONNEMENT BOBINE 2300

R299.197.030

Recommended Stripping dimensions of the RG58 cable for R3C male R299.197.030

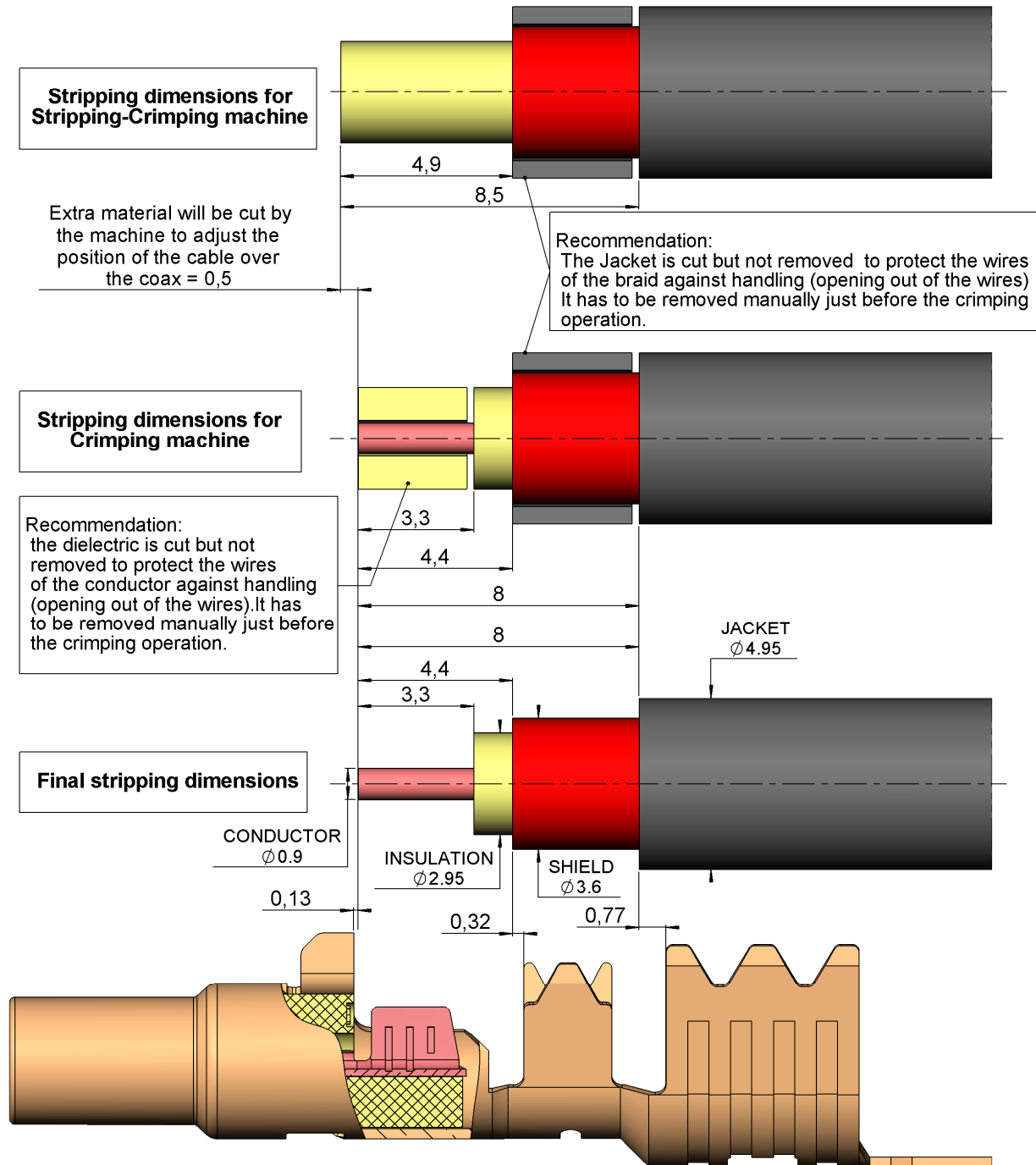

PATENTED

Issue : 0748 B

In the effort to improve our products, we reserve the right to make changes judged to be necessary.

RADIALL 

R3C MALE COAX CAB 5/50

CONDITIONNEMENT BOBINE 2300

R299.197.030

crimping height **			
conductor X	braid Y	jacket Z	conductor/body W
1,18±0,05	3,7+0,05/-0,1	4,8+0,05/-0,1	2,65±0,05

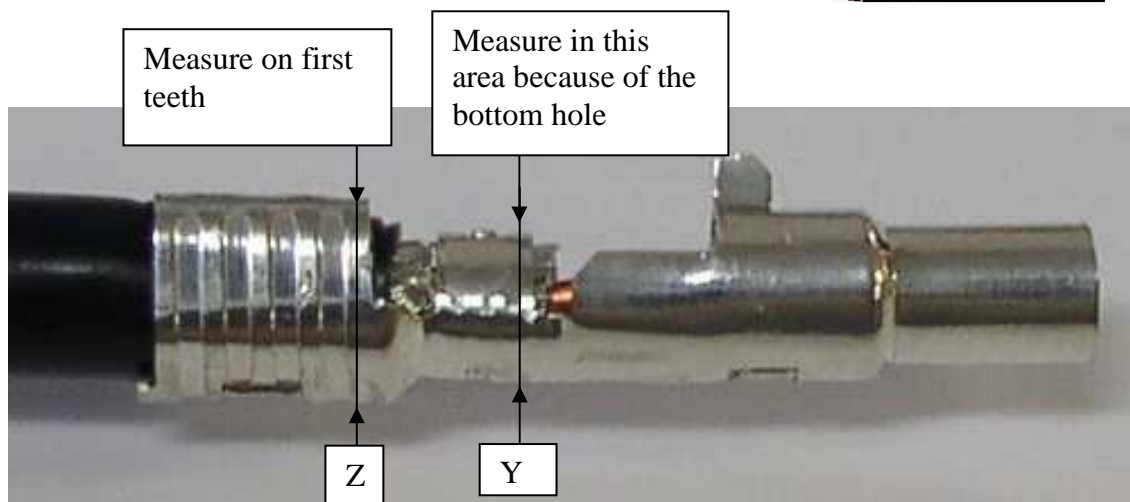
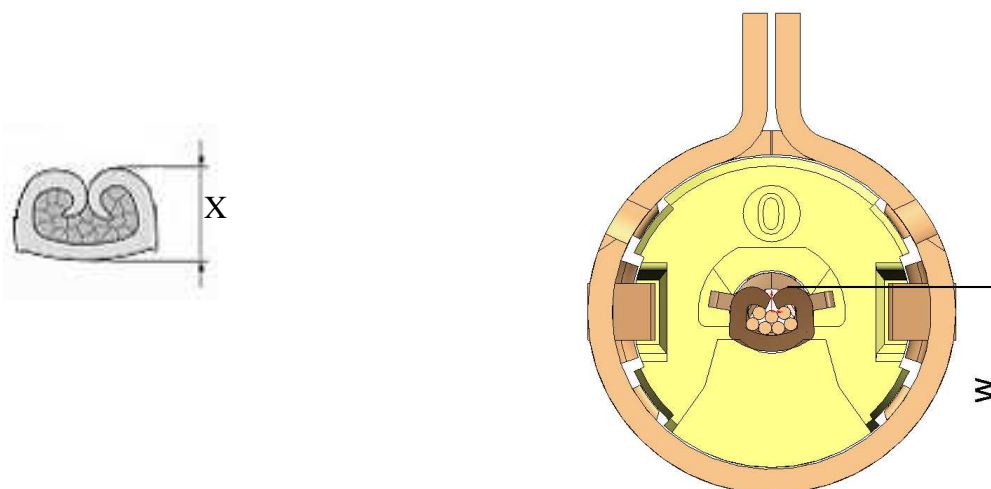

**** CAUTION**

- Before using applicator, make sure the press is calibrated :135,8 mm from the lower dead point up to the base
- Crimping height may change depending on the manufacturer of the cable, for more informations please contact us
- We recommend to make electrical test after each set up of the applicator:
 - Outer and center contact continuity+Dielectric withstanding voltage 800Vrms, 50Hz
 - Insulation resistance 1000 Mohms
 - Cable retention = 110Newton mini during 5 seconds with electrical continuity

Issue : 0748 B

In the effort to improve our products, we reserve the right to make changes judged to be necessary.

